

The antenna for IoT: NB-IoT, LoRa, Zigbee or Sigfox

- **Product:** RUN mXTEND™ FR01-S4-224
- **Dimensions:** 12.0 mm x 3.0 mm x 2.4 mm
- **Frequency regions:** 698-960 MHz, 1710-2690 MHz and 3400-3800 MHz

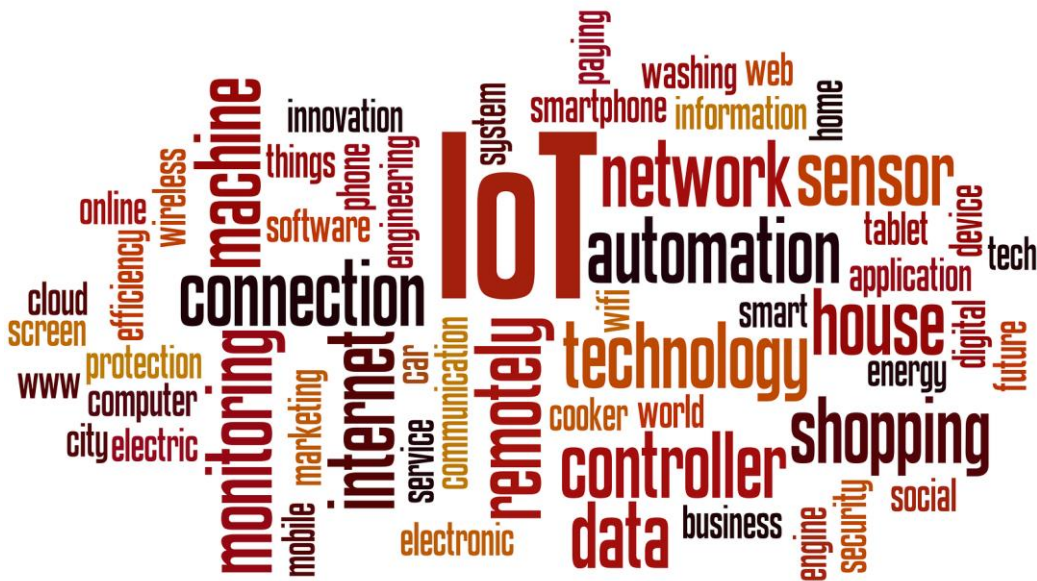

Do you need an antenna for **NB-IoT**? Use the RUN mXTEND™. Do you need an antenna for **LoRa**? Use the RUN mXTEND™. Do you need an antenna for **Sigfox**? Use the RUN mXTEND™. Doubts about the selection of a **licensed or unlicensed IoT standard**? The RUN mXTEND™ will be the choice anyway.

Forget antenna size, antenna shape, antenna placement, even antenna frequency! Choosing the right antenna for your IoT applications will never be a challenge any more, the antenna leaves the role of critical component and assumes one where the antenna becomes an **off-the-shelf** chip component **able to be tuned as needed**.

Our team has developed the RUN mXTEND™ chip antenna component that enables worldwide full performance and connectivity in all the frequency bands of operation for the Internet of Things. The RUN mXTEND™ antenna booster, and its versatility, is one of the best options to **go wireless** having any type of IoT platform because **one antenna covers the IoT frequency bands**. Using the mXTEND™ family you will be part of a new technology that will **save you cost, design time and risk**.

Find in this IoT application note how the same chip antenna component will operate at the frequency band you need in the **smallest package** ever.

TABLE OF CONTENTS

1.	PRODUCT DESCRIPTION FR01-S4-224	3
2.	ONE ANTENNA, MANY DEVICES	4
2.1.	PERFORMANCE IN DIFFERENT PCB SIZES	4
2.2.	VSWR AND EFFICIENCY	5
2.3.	MATCHING NETWORK.....	5

1. PRODUCT DESCRIPTION FR01-S4-224

The market for the Internet of Things continues to grow and the expanding diversity of IoT devices means product configurations are endless. For this application note we have tested the RUN mXTEND™ chip antenna component's (FR01-S4-224) performance when mounted onto various sized ground planes. We show the impact of ground plane size on performance in order to provide the most relevant results for those who design IoT devices of various dimensions. Additionally, we illustrate how to use the RUN mXTEND™ chip antenna component for operating at the ISM bands, which are frequently used in IoT devices.



Material: The RUN mXTEND™ Antenna Booster is built on glass epoxy substrate.

APPLICATIONS

- Smart Metering
- Smart City & Smart Building
- Industrial IoT
- Remote monitoring and control
- Sensors
- Personal & Asset Tracking
- Fleet management
- RFID
- Retail
- Security Systems
- Smart Home
- Medical

BENEFITS

- High efficiency
- Small size
- Cost-effective
- Easy-to-use (pick and place)
- Multiband behaviour (worldwide standards)
- Off-the-Shelf Standard Product (no customization is required)

The RUN mXTEND™ Antenna Booster (FR01-S4-224) provides multiband performance in wireless devices throughout a large range of frequencies (698-960 MHz, 1710-2690 MHz and 3400-3800 MHz), enabling worldwide coverage and allowing operation in **multiple IoT related communication standards** such as **NB-IoT, LoRa, Zigbee, SigFox, Neul, Thread, Z-Wave, Weightless**, all **mobile GSM/UMTS/LTE** bands for **2G, 3G, 4G, 5G, Bluetooth** and **WIFI**. Based on Fractus Antennas' proprietary Virtual Antenna™ technology, the RUN mXTEND™ belongs to a new generation of antenna products focused on replacing conventional antenna solutions with miniature, off-the-shelf components that drive fast, intelligent design. This breakthrough technology has been specifically designed to fit a diverse set of wireless applications – IoT devices are just one of the many environments where this tiny antenna can be transformational.

2. ONE ANTENNA, MANY DEVICES

2.1. PERFORMANCE IN DIFFERENT PCB SIZES

For demonstration purposes, the performance of the RUN mXTEND™ chip antenna component is measured in different PCB boards within the 863-928 MHz frequency range as used in IoT standards such as NB-IoT, LoRa, Zigbee and SigFox. Please notice that the RUN mXTEND™ is able to cover a much wider range of frequencies and standards; if your IoT device is to operate in any other band within the 698MHz to 3800MHz range you are welcome to contact support@fractusantennas.com for assistance.

Each PCB board in the following set-up integrates a UFL cable to connect the RUN mXTEND™ Antenna Booster with a SMA connector so that VSWR and antenna efficiency can be tested. The following results cover a wide scope of ground plane sizes (length and width), ranging from 75mm x 54mm down to 40mm x 20mm.

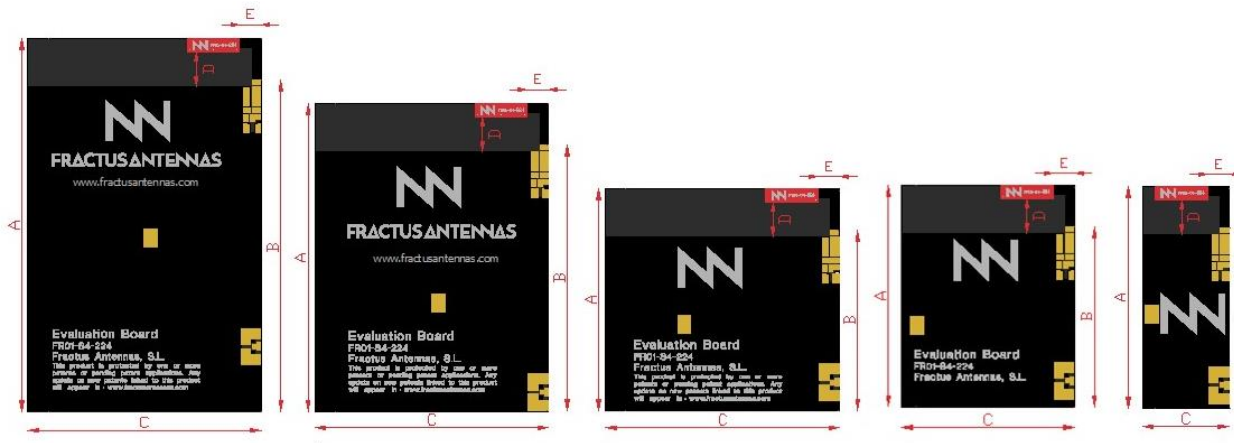

Figure 1 – Evaluation boards with different ground plane dimensions that provide operation from 863 MHz to 928 MHz.

Measure	mm
A	86 - 51
B	75 - 40
C	54 - 20
D	8
E	5

Tolerance: ±0.2 mm

D: Distance between the RUN mXTEND™ Antenna Booster and the ground plane.

Material: The Evaluation Board is built on FR4 substrate. Thickness is 1 mm.

2.2. VSWR AND EFFICIENCY

VSWR (Voltage Standing Wave Ratio) and Total Efficiency versus Frequency (GHz).

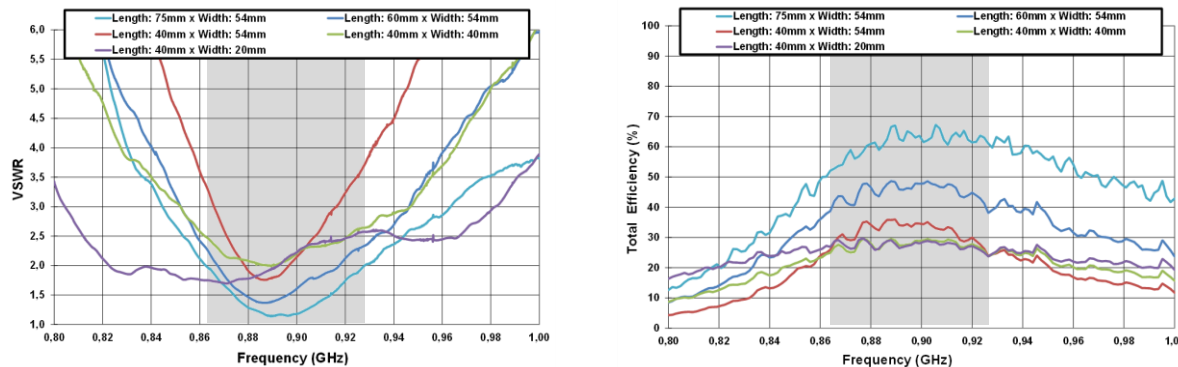

Figure 2 – VSWR and Total Efficiency for the 863 – 928 MHz frequency range (Figure 1).

Dimensions (B x C)	LFR (863 – 928MHz)				
	η_a 863MHz	η_a 928MHz	Min	Max	Av. η_a
75mm x 54mm	50.8	59.7	50.8	67.3	61.2
60mm x 54mm	38.1	39.1	38.1	48.6	45.0
40mm x 54mm	25.3	24.4	23.9	35.9	31.7
40mm x 40mm	24.6	24.3	23.7	29.5	27.5
40mm x 20mm	27.1	24.5	23.7	29.7	27.4

Table 1 – Total efficiency (%) comparison considering the different dimensions.

2.3. MATCHING NETWORK

The matching network design and value components for each device and PCB size is provided here. While the antenna component and matching network design and topology remains the same, the value of the components will be adapted to every PCB size for an optimum performance. The specs of a Fractus Antennas standard product are measured in a reference evaluation board, to isolate the antenna performance from other system elements. However, when incorporating into real designs, nearby components such as LCD's, batteries, covers and connectors may affect the antenna performance. For this reason, placing pads compatible with 0402 and 0603 SMD components for a matching network as close as possible to the feeding point is highly recommended. The matching network should be implemented in the ground plane area rather than the clearance area, this will provide a degree of freedom for tuning the RUN mXTEND™ antenna component once the design is finished, taking into account all elements of the system (batteries, displays, covers, etc.).

Please notice that different devices with different ground planes and different components nearby the RUN mXTEND™ antenna component may require a fine tuning of the matching networks. To ensure optimal results, the use of high Q and tight tolerance components is highly recommended (Murata components).

If you need assistance, please contact support@fractusantennas.com for more information related to our chip antenna component matching service.

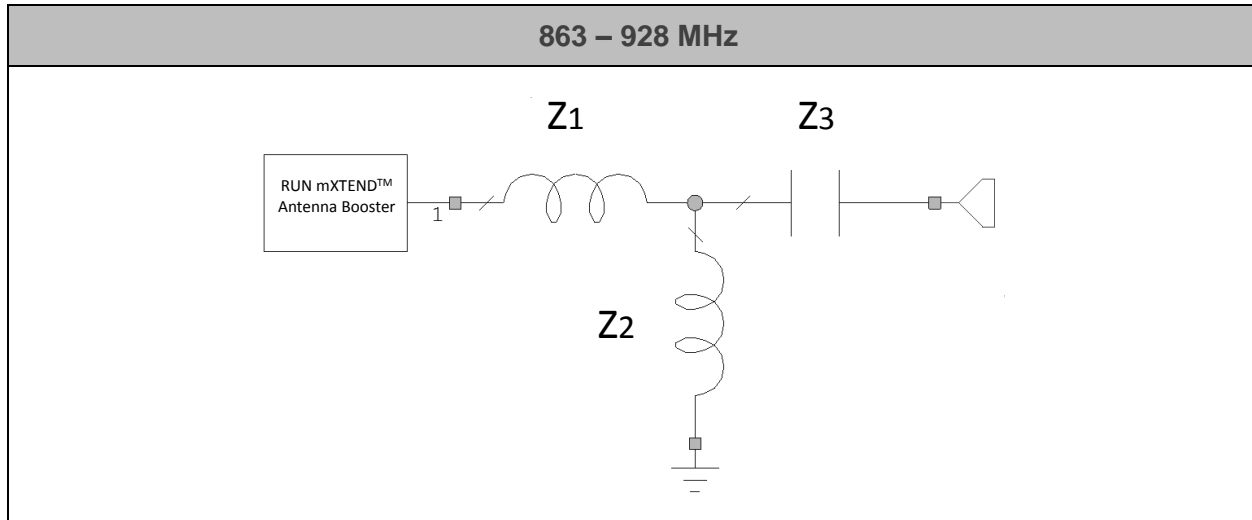

Figure 3 – Topology of matching network mounted for the different solutions.

Dimensions (B x C)	Z ₁	Z ₂	Z ₃
75mm x 54mm	24nH	7.5nH	1.8pF
60mm x 54mm	25nH	6.8nH	1.8pF
40mm x 54mm	25nH	7.2nH	1.5pF
40mm x 40mm	27nH	7.2nH	2.1pF
40mm x 20mm	27nH	8.2nH	2.0pF

Table 2 – Values of the components for each different solution.

Value		Part Number
Z ₁	24nH	LQW18AN24NG00
	25 nH	LQW18AN25NG80
	27 nH	LQW18AN27NG80
Z ₂	7.5 nH	LQW18AN7N5C80
	6.8 nH	LQW18AN6N8C10
	7.2 nH	LQW18AN7N2C80
	8.2 nH	LQW18AN8N2C80
Z ₃	1.8 pF	GJM1555C1H1R8WB01
	1.5 pF	GJM1555C1H1R5WB01
	2.1 pF	GJM1555C1H2R1WB01
	2.0 pF	GJM1555C1H2R0WB0

Table 3 – Values and part numbers of the components used for the matching networks for the cases with dimensions 75mm x 54mm, 60mm x 54mm, 40mm x 54mm, 40mm x 40mm, 40mm x 20mm.

Fractus Antennas products are protected by [Fractus Antennas patents](#).

All information contained within this document is property of Fractus Antennas and is subject to change without prior notice. Information is provided “as is” and without warranties. It is prohibited to copy or reproduce this information without prior approval.

Fractus Antennas is an ISO 9001:2015 certified company. All our antennas are lead-free and RoHS compliant.

ISO 9001: 2015 Certified



This project has received funding from the European Union's Horizon 2020 research and innovation programme under grant agreement N° 674491

